

Technical Report

CMU/SEI-87-TR-042

ESD-TR-87-205

January 1988

Issues in Software: A Blue Two Visit Feasibility Assessment



William E. Hefley

Software Engineering Institute

Capt. Benita L. Gilliard
CMSgt. Charles M. Worm

Air Force Coordinating Office for Logistics Research

Landon O. Sager

Inter-Command Electronic Warfare Management Directorate

Software Engineering Institute

Carnegie Mellon University
Pittsburgh, Pennsylvania 15213

This technical report was prepared for the

SEI Joint Program Office
ESD/XRS
Hanscom AFB, MA 01731

The ideas and findings in this report should not be construed as an official DoD position. It is published in the interest of scientific and technical information exchange.

Review and Approval

This report has been reviewed and is approved for publication.

FOR THE COMMANDER

Karl H. Shingler SIGNATURE ON FILE
SEI Joint Program Office

This work is sponsored by the U.S. Department of Defense.

Copyright © 1987 by the Software Engineering Institute

This document is available through the Defense Technical Information Center. DTIC provides access to and transfer of scientific and technical information for DoD personnel, DoD contractors and potential contractors, and other U.S. Government agency personnel and their contractors. To obtain a copy, please contact DTIC directly: Defense Technical Information Center, Attn: FDRA, Cameron Station, Alexandria, VA 22304-6145.

Copies of this document are also available through the National Technical Information Services. For information on ordering, please contact NTIS directly: National Technical Information Services, U.S. Department of Commerce, Springfield, VA 22161.

Ada is a registered trademark of the U.S. Government, Ada Joint Program Office. DECSYSTEM-10 and VAX are trademarks of Digital Equipment Corporation. IBM is a registered trademark of International Business Machines Corporation. PS 2 is a trademark of Evans and Sutherland.

Issues in Software: A Blue Two Visit Feasibility Assessment

Abstract

The Software Engineering Institute (SEI) participated in a series of fact-finding meetings sponsored by the Air Force Coordinating Office for Logistics Research (AFCOLR) to gather information necessary to set the scope for and to implement one or more Blue Two Visits on software. The purpose of a typical Blue Two Visit (BTV) is to introduce to industry's top design engineers and program managers the day-to-day constraints Air Force maintainers face on front-line operations bases. The participants experience first-hand the effects of design on maintenance. This exposure has been significant in bridging the gap between DoD and industry in understanding, documenting, and supporting Air Force weapon system requirements to increase combat supportability.

This report documents discussions, which attempt to address the following questions for a software-oriented BTV:

1. Do software maintainers and users have messages for software designers and programmers?
2. What are these messages?
3. How can these be best communicated?
4. To whom should these messages be targeted?
5. What should the BTV be called?

Participants at these meetings included personnel from the SEI, AFCOLR, Inter-Command Electronic Warfare Management Directorate (ASD/RWA), Ogden Air Logistics Center, Warner Robins Air Logistics Center, 388th Tactical Fighter Wing (TAC), Detachment 1 of the 49th Test Squadron, Air Force Operational Test and Evaluation Center (AFOTEC) B-1B FOT & E Test Team, 96th Bombardment Wing (Heavy) (SAC), and Headquarters, Strategic Air Command. The issues raised by the participants in the various discussions did not necessarily describe all concerns affecting software development, maintenance and enhancement in Air Force systems, but did provide insights into significant technical and management considerations of Air Force software maintainers. These considerations fell primarily within six areas:

1. weapon system orientation
2. acquisition issues
3. post deployment software support issues
4. software development issues
5. supportability and testability issues
6. personnel management issues

1. Introduction

1.1. Blue Two Visit Program

The Blue Two Visit (BTV) program, managed by the Air Force Coordinating Office for Logistics Research (AFCOLR), exposes corporate program managers, senior design engineers, and appropriate Air Force systems acquisition personnel to "real world" operating and maintenance procedures and constraints. The program does this by facilitating direct communication between these key decision planners, developers and the day-to-day maintainers of current Air Force weapon systems. The BTV goal is to allow face-to-face interaction between maintainers and industry designers and program managers in order to influence future weapon systems and support equipment designs to be more reliable and easier to maintain. By coordinating interaction between the technology providers and the technology users through "hands-on" exposure within the operating environment, the BTV program has influenced designers to incorporate reliability, maintainability, and supportability features into future weapon systems.

Originally known as "Contractor Visits to the Field," the BTV program began in December 1983, by the initiative of AFCOLR, the Joint Advanced Fighter Engine Program Office, and LtGen Leo Marquez, then Deputy Chief of Staff, Logistics and Engineering, HQ USAF. In September 1985, the program was officially redesignated Blue Two Visit, referring to the Air Force "Two Striper" (Airman) maintainer. Initial field visits centered on a small class of known operational reliability and maintainability ills specific only to aircraft systems including safety wire, corrosion, hydraulic leaks, non-interchangeable components, etc., and addressed common service problems and methods for overcoming faulty design. From aircraft systems, the program expanded significantly in 1986 to include new acquisition of aircraft; missiles; and command, control, communications, and intelligence systems (C³I); in addition to existing components and support structures.

The BTV forum is an immersion in the total maintenance experience — the harsh weather, the long hours, the lack of spare parts — where corporate presidents and industry's aerospace design engineers can be "maintainers for a day." During visits, participants are required to put in long hours on flight lines, often "suing up" in chemical/biological/radiological gear, and perform routine maintenance tasks — often times on a system their company has designed. As a result of the experience, the Air Force is witnessing a renewed commitment from industry in meeting Air Force reliability and maintainability goals.

Since conception, the field visit effort has matured to a premier Air Force program for identifying and addressing reliability and maintainability concerns. To date, there have been 28 Blue Two Visits with 535 contractors (representing 165 companies), 249 DoD and 3 academic personnel participating. The 28 BTVs have visited 78 units. The BTV program is continuing to gain recognition and support. Planned BTVs include:

- Electronic Warfare Sep 87
- Electronics/Avionics Nov 87

- Aircraft Support (AAC) Jan 88
- Aircraft Support (PACAF) Feb 88
- Structures/Fasteners/Composites Apr 88
- Aircraft Engines Jun 88
- Aircraft Support (USAFE) Aug 88
- Tactical Weapons Oct 88

In addition, major USAF commands are being encouraged to set up their own BTV programs. This was emphasized by General Piotrowski, Headquarters USAF/CV, in his Reliability and Maintainability Policy Letter #3: Blue Two Visit urging that BTV program become a mandatory part of the acquisition process. Such a program has been established at Hill AFB in Ogden. Ogden Air Logistics Center (OO-ALC) personnel have visited the shops at the 388th Tactical Fighter Wing, and the Advanced Tactical Fighter System Program Manager at the Sacramento Air Logistics Center has brought Advanced Tactical Fighter (ATF) contractor teams to Hill AFB for visits. Other Air Force activities have established similar orientation-type programs under various titles which parallel BTV objectives.

1.2. Software Blue Two Visit

With software becoming an increasingly essential and expensive element of defense systems' acquisition and life cycle support costs, AFCOLR was directed by the Assistant Secretary of the Air Force for Logistics, to investigate the feasibility of one or more Blue Two Visits on software. However, because of software's complex but sensitive nature, it does not lend itself easily to the "hands-on" operating and maintenance exposure typical of a hardware BTV. For these reasons, a fact-finding team was formed to attempt to answer several questions in order to properly set the scope for and implement a successful software-oriented BTV. These questions include:

- Do software maintainers and users have messages for software designers and programmers?
- What are these messages?
- How can these be best communicated?
- To whom should these messages be targeted?
- What should the BTV be called?

These questions have provided a framework for gathering data across all visited Air Force maintainers, including organizational level maintainers in the units at the front-line operations bases, depot-level maintenance personnel at the Air Logistics Centers, and maintenance evaluators for new weapons systems.

1.3. Feasibility Assessment

This broad approach to examining Air Force software maintenance provides the greatest potential for obtaining a comprehensive overview and for identifying the numerous interrelated messages that should be communicated to defense contractors and Air Force acquisition personnel in a software-related BTV. This report:

- Documents the activities of the AFCOLR-sponsored fact-finding team.
- Summarizes the significant technical and managerial considerations reported by Air Force software maintainers.
- Provides recommendations to Blue Two Visit program management regarding the feasibility of a software-oriented Blue Two Visit.

2. Fact-finding Visits

The fact-finding team assembled by AFCOLR conducted a number of visits to investigate the feasibility and projected scope of a software-oriented BTV. The AFCOLR Software BTV fact-finding team consisted of the individuals shown in Table 2-1. Appendix B to this report lists all participants in the fact-finding visits.

AFCOLR Software BTV Fact-finding Team		
Capt. Benita L. Gilliard	Information Systems Branch Chief, Plans and Programs Division, Air Force Coordinating Office for Logistics Research	AFCOLR/XRI (HQ USAF)
Capt. Daniel R. Bliss	Data Systems Development Officer, Logistics Maintenance Management Data Branch, Headquarters, Strategic Air Command	HQ SAC/LGMMMD
CMSgt. Charles M. Worm	Blue Two Visit Program Manager, Independent Research & Development Branch, Maintenance and Engineering Division, Air Force Coordinating Office for Logistics Research	AFCOLR/MEI (HQ USAF)
Landon O. Sager	Logistics Management Specialist, Inter-Command Electronic Warfare Management Directorate (ICEWMD), Aeronautical Systems Division	ASD/RWA
William E. Hefley	Member of the Technical Staff, Technology Transition	Software Engineering Institute

Table 2-1: AFCOLR Fact-Finding Team

To better understand the environment in which mission-critical software is maintained, key software-intensive sites were chosen. The AFCOLR-sponsored team visited several Air Force facilities involved in software acquisition, support, and maintenance. Each facility was selected on the basis of its intensive involvement in aircraft weapon systems. Major organizations contributing to the success of this software-oriented BTV feasibility assessment are shown in Figure 2-1.

This team visited the Ogden Air Logistics Center, Hill AFB, UT, and the 96th Bombardment Wing, Dyess AFB, TX, during 10-14 August 1987. Additional meetings were held at the Warner Robins Air Logistics Center, Robins AFB, GA, 2-3 September 1987.

At each of these meetings, participants were briefed on the BTV program and the AFCOLR effort to include software in the BTV program. Participants then discussed their view of software within their day-to-day functions. These discussions primarily addressed mission-critical computer

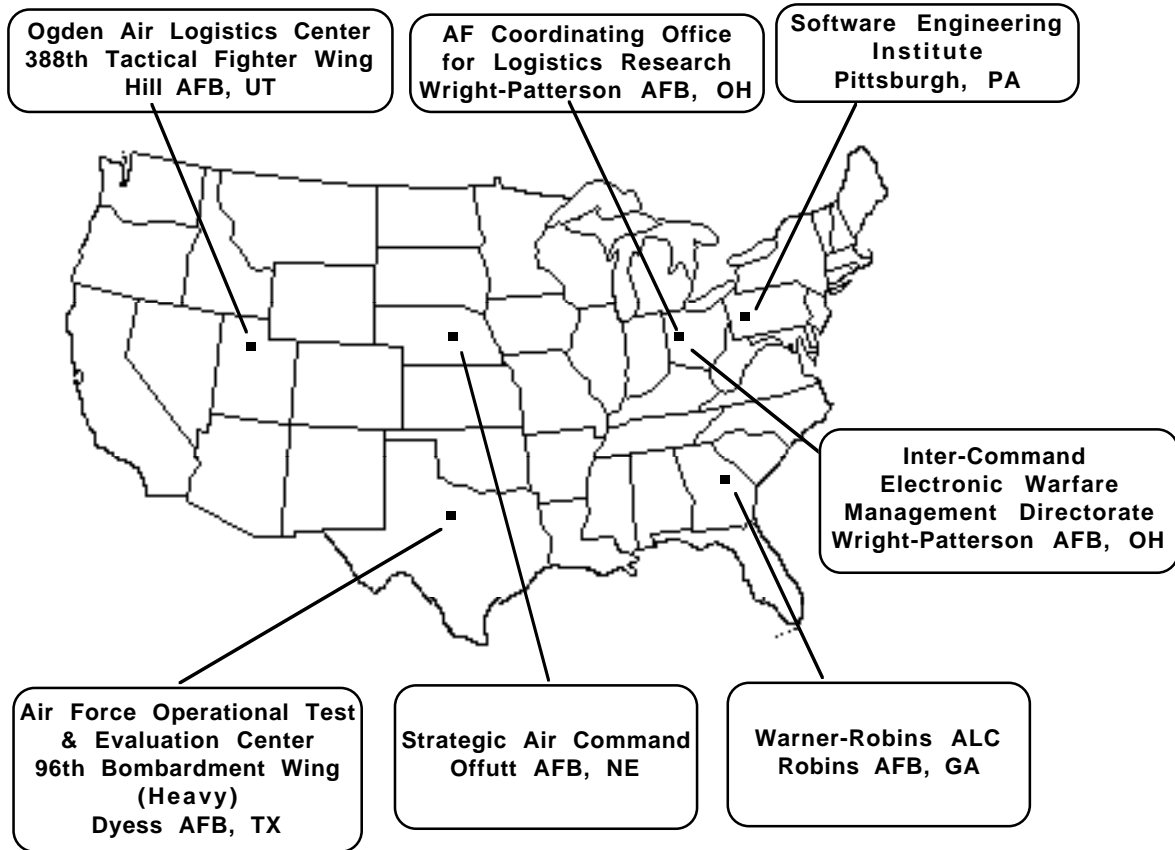

Figure 2-1: Major Participants in this Feasibility Assessment

resources software issues as they pertain to Air Force aircraft weapon systems. It is sometimes necessary to differentiate aircraft weapon system software from software systems employed in other weapon systems, such as air defense or command, control, communications and intelligence (C³I) systems.

As part of the pre-visit coordination, participating organizations were provided the major questions and concerns (para. 1.2) that would be discussed. The discussions were conducted using these five questions as guidelines with anonymity assured to the participants due to the potentially controversial nature of some of the issues being discussed. A summation of these discussions is contained in Section 3, Software Issues.

2.1. Hill Air Force Base

The fact-finding team visited the Ogden Air Logistics Center (OO-ALC), Hill AFB, UT, on 11 August 1987. The OO-ALC is responsible for depot-level support for the F-16 fighter aircraft. The host for this meeting was Mr. Rick Holsman, Branch Chief for the Aircraft Computer Resources Branch (MMEC) within the Engineering Division of the Directorate of Material Management.

OO-ALC has the System Program Manager (SPM) responsibility for the F-16 fighter, providing the management and engineering support for the weapon system including the Avionics Integration Support Facility (AISF). The AISF is an applied engineering laboratory designed to support digital airborne systems and subsystems and associated programs and equipment.

In addition to the Ogden Air Logistics Center, Hill AFB is also home to the 388th Tactical Fighter Wing, a Tactical Air Command (TAC) wing flying the F-16A/B aircraft with responsibility for organizational and intermediate level communication, navigation and avionics systems maintenance.

OO-ALC engineers and managers, as well as F-16A/B maintainers from the 388th Tactical Fighter Wing, contributed to the discussions. With this range of representation from both software maintainers and software users, Hill AFB was an excellent starting point for the fact-finding discussions. Attendees are shown in Table 2-2, and Appendix B lists the attendee's contact information.

The team was briefed by Mr. Bruce W. Rudd of the F-16 Fire Control/HUD OFP Development Section (OO-ALC/MMECA) on post deployment software support (PDSS) concerns facing Hill AFB and the software maintenance community. It is OO-ALC's position that many of the software issues today focus on the Air Force's ability to use and manage its mission critical computer resources (MCCR). This briefing is contained in Appendix C.

The impact of maintenance for these systems is often given second place in the acquisition arena. OO-ALC would suggest that systems be designed and delivered with PDSS in mind. They cite three areas of concern:

- software
- documentation
- support tools

In each of these areas, the OO-ALC briefing expands on what can be done in these important areas to adequately ensure that a supportable system is delivered. In summary, they present that the major problem is in complying with and ensuring compliance with established methods of software engineering, and not necessarily with awareness of what is needed to develop and deliver supportable software systems.

Ogden Air Logistics Center		
Rick Holsman	Aircraft Computer Resources Branch Chief, Engineering Division, Directorate of Material Management	OO-ALC/MMEC
Major Gary S. Hochstetler	Aircraft Computer Resources Branch (AFRES IMA assignee)	OO-ALC/MMEC
Leon Oldham	F-16 Radar/Stores OFP Development Section Chief	OO-ALC/MMECR
Bruce W. Rudd	F-16 Fire Control/HUD OFP Development Section	OO-ALC/MMECA
Robert Sharp	Software Support Center Branch, Missile and Aircraft Systems Division, Directorate of Maintenance	OO-ALC/MAKTF
Bill Frost	F-4 AISF Section	OO-ALC/MMECT
388th Tactical Fighter Wing		
TSgt. Jeffrey A. Carey	Integrated Avionics Branch, 388 Component Repair Squadron	388 CRS/MACIA
TSgt. Rudulph W. Peart	Integrated Avionics Branch, 388 Component Repair Squadron	388 CRS/MACIA
SSgt. Christopher B. Gifford	388 Aircraft Generation Squadron	388 AGS/MAABC

Table 2-2: Participants from Hill AFB

2.2. Dyess Air Force Base

The fact-finding team visited the 96th Bombardment Wing (Heavy), Dyess AFB, TX, on 13 August 1987. The 96 BMW is a Strategic Air Command wing flying the B-1B bomber. The 96 BMW host for this meeting was Captain Steve Hackett, Central Integrated Test System (CITS) Maturation Officer (MAMC) within the Maintenance Control Division reporting to the Deputy Commander for Maintenance.

Dyess AFB provided additional perspectives into the nature of what the messages for a software-oriented BTM might be. Not only did the 96 BMW provide support for the main discussions, they also provided thought-provoking side discussions and an opportunity to tie all these concepts together by visiting the flight line and seeing a B-1B bomber in the hanger undergoing normal maintenance. In addition to the wing's mission-oriented emphasis on the B-1B bomber, the Air Force Operational Test and Evaluation Center (AFOTEC) personnel of the B-1B FOT & E Test Team participated in these discussions. Attendees are shown in Table 2-3, and Appendix B contains the attendee's contact information. The main elements of these discussions are included in Section 3, Software Issues.

96th Bombardment Wing (Heavy)		
Capt. Steve Hackett	CITS Maturation Officer, Maintenance Control Division, Deputy Commander for Maintenance	96 BMW/MAMC
CMSgt. Robert Lewis	NCOIC, Maintenance Systems Analysis, Maintenance Control Division, Deputy Commander for Maintenance	96 BMW/MAP
Air Force Operational Test & Evaluation Center		
Major Gary F. Giesecke	Deputy for Software, AFOTEC B-1B FOT & E Test Team	AFOTEC FOT & E/TDS
Capt. Glenn Tuley	Deputy for Software, AFOTEC B-1B FOT & E Test Team	AFOTEC FOT & E/TDS
1Lt. Rich Dale	Deputy for Software, AFOTEC B-1B FOT & E Test Team	AFOTEC FOT & E/TDS
2Lt. Emily Andrew	Deputy for Software, AFOTEC B-1B FOT & E Test Team	AFOTEC FOT & E/TDS
MSgt Mel Noble	Maintenance Evaluator for Avionics Maintenance Squadron, AFOTEC B-1B FOT & E Test Team	AFOTEC FOT & E/TDLA
SSgt. W. R. Wanamaker	Maintenance Evaluator for Avionics Maintenance Squadron, AFOTEC B-1B FOT & E Test Team	AFOTEC FOT & E/TDLA

Table 2-3: Participants from Dyess AFB

2.3. Robins Air Force Base

The fact-finding team visited the Warner Robins Air Logistics Center (WR-ALC), Robins AFB, GA, on 2-3 September 1987. The WR-ALC hosts for these meetings were Mr. John J. LaVecchia, Branch Chief for the Engineering and Reliability Branch (MMRR) within the Electronic Warfare (EW) Management Division of the Directorate of Material Management, and Mr. Larry K. Israel, Branch Chief for the Software Support Center Branch (MAIT) within the Airborne Electronics Division of the Directorate of Maintenance.

WR-ALC provided the opportunity to explore issues regarding types of weapons systems software that were not part of the digital avionics software flying the aircraft, such as electronic warfare software and automatic test equipment (ATE) software. Attendees are shown in Table 2-4, and Appendix B contains the attendee's contact information.

By direction of a Program Management Directive (PMD), WR-ALC establishes the electronic warfare avionics integration support facility (EWAISF), which provides services to achieve organic

Warner Robins Air Logistics Center		
John J. LaVecchia	Engineering and Reliability Branch Chief, Electronic Warfare (EW) Management Division, Directorate of Material Management	WR-ALC/MMRR
Harry Jennings	Emergency Reprogramming Center, Simulation and Evaluation Section	WR-ALC/MMRRA
Dorothy Jackson	EF-111/ALQ-125 Unit, EW Integrated Systems Section	WR-ALC/MMRRIC
Joseph Watwood	APR-38 Unit, EW Integrated Systems Section	WR-ALC/MMRRIA
Michael S. Tipton	EW Active Systems Section	WR-ALC/MMRRC
William Calkins	Radar Warning Receiver Section	WR-ALC/MMRRV
Roy P. Oliver	ALR-74/F-15 TEWS Unit, Radar Warning Receiver Section	WR-ALC/MMRRVE
William Raymond Haggard	Integration Support Facility Operations Branch, Systems Engineering Division, Directorate of Material Management	WR-ALC/MMEC
Larry K. Israel	Software Support Center Branch Chief, Airborne Electronics Division, Directorate of Maintenance	WR-ALC/MAIT
Lonnie Y. Totty	Radar and Space Communications Section Chief	WR-ALC/MAITB
Jerry L. Watts	Countermeasures Unit Chief, Radar and Space Communications Section	WR-ALC/MAITBC
Charles R. Singleton	Tactical Support Section Chief	WR-ALC/MAITC
Jim Mosely	F-15 Radar Support Unit, Tactical Support Section	WR-ALC/MAITCA

Table 2-4: Participants from Robins AFB

USAF support capabilities for all present and future reprogrammable airborne EW systems. The EW Management Division (WR-ALC/MMR) is responsible for the following EW system elements:

- management of items and components
- hardware engineering
- EW software engineering
- reprogramming management and support
- total EW system and subsystem engineering, including integration

- configuration management
- documentation
- coordination with SPO to ensure acquisition of proper support tools

The Software Support Center (WR-ALC/MAIT) performs maintenance and support for existing automatic test equipment (ATE) software for all items repaired by WR-ALC/MAI, and all items prime at WR-ALC (items not repaired by another ALC) as well as developing ATE software and providing acquisition support and technology development. The Software Support Center is also responsible for:

- unit under test (UUT) test software support
- ATE system level software support
- technical support to System Program Managers/Item Managers
- technical assistance to the technology repair centers
- consulting assistance to organizations responsible for acquiring ATE and support facilities
- production of software and firmware for distribution to users
- development of test program sets (TPS) for WR-ALC prime systems

3. Software Issues

This section attempts to paraphrase the various concerns and messages expressed by U.S. Air Force personnel, both in and out of uniform, who met with the AFCOLR-sponsored fact-finding team at the various locations. To cite an earlier SEI study:¹

Our field research has revealed that many of the individuals involved in software acquisition view software maintenance as substantially similar to hardware maintenance. This orientation often fails to appreciate the complexity of software maintenance, and the continuing importance of acquiring the technology needed to maintain the software. To gain this kind of appreciation, it is necessary to understand the unique characteristics of software maintenance as well as the role maintenance plays in the software life cycle.

The fact-finding team participated in discussions with software maintainers and system users, as described in Section 2, to be able to understand these characteristics of software maintenance and to be able to incorporate these thoughts into the process of planning for one or more software-oriented Blue Two Visits. The issues raised by the participants in the various discussions did not necessarily describe all the concerns affecting software development, maintenance, and enhancement in Air Force systems but did provide insights into significant technical and management considerations of Air Force software maintainers.

These considerations fell primarily within six areas. They are:

1. weapon system orientation
2. acquisition issues
3. post deployment software support issues
4. software development issues
5. supportability and testability issues
6. personnel management issues

Regardless of the breadth or number of the issues raised during these discussions, the overwhelming attitude of the Air Force personnel was that "We in Maintenance get the job done in spite of ...".

3.1. Weapon System Orientation

One of the difficult views to communicate to defense contractor personnel on a Blue Two Visit is that to the end users of a major weapon system, it is just that — a *system*. The developers or maintainers may see it as a loose collection of software and hardware but, by the time it reaches the field, it has become a singular system designed to support a mission-critical need. Participants in these discussions agreed that there appears to be an increasing trend towards the

¹*The Effect of Software Support Needs on the Department of Defense Software Acquisition Policy: Part 1 - A Framework for Analyzing Legal Issues*, Anne C. Martin and Kevin M. Deasy, Technical Report CMU/SEI-87-TR-2 (ESD-TR-87-102), January 1987

development and procurement of generic hardware, while software is rapidly becoming the distinguishing factor in today's weapon systems. Participants reported that it currently takes three to five years to implement a functional change in hardware, including time to get the modification kits delivered and installed on the aircraft. A software change can be implemented on the aircraft in twelve to eighteen months (or less, in some instances), including the technical order changes, if any. Maintainers perceive that the mindset evident today among managers and decision makers is that a software change is therefore cheaper than a hardware change. Invariably, maintainers report that any change impacts software, and software updates are expensive.

Software maintenance is performed at the depot level, typically at an Air Logistics Center (ALC) or contractor facilities. Intermediate shop-level maintainers fault isolate boxes down to the level of the shop replaceable unit, while organizational maintainers fault isolate the systems down to the line replaceable unit (LRU). Organizational maintainers also load new software into the aircraft, typically by installing new memory cards or reloading memory using a memory loader/verifier. Issues such as DoD-STD-2167 and post deployment software support are not of immediate interest to the maintainers at the organizational and intermediate levels, as their emphasis is on the system and the boxes that comprise the system. In fact, these discussions led to the conclusion that there are several levels of individuals interested in some facet of aircraft operational and test software. These levels include: depot, intermediate and organizational maintainers, and users preparing mission data parameters to be used as part of the systems. These various levels are shown in Table 3-1.

Users -

Organizational	Use operational flight programs (OFF) in performance of unit mission. Use built-in-test (BIT) or operational test programs (OTP) to diagnose systems to the level of a faulty LRU.
Intermediate	Use diagnostics and automated test equipment (ATE) to diagnose systems to the level of a faulty module in a LRU. Use ATE systems software provided with ATE.
Depot	Performs intermediate functions in addition to the use of diagnostics and automated test equipment (ATE) to diagnose systems to the level of a faulty component in a module. Use ATE systems software provided with ATE.

Maintainers -

Users	Headquarters-level or equivalent preparing mission data parameter sets using automated mission planning systems. For example, the Strategic Mission Data Planning System (shown in Figure 3-2) provides mission data for the B-1B aircraft OFF. Other similar systems exist, such as TAC's Mission Support System or the TAWC for the AN/ALQ-131 system. The Area Reprogramming Capability (ARC) is being developed to provide this capability for all EW systems.
ALC	MM offices responsible for maintenance of operational flight programs (OFF) and built-in-test (BIT). MA offices responsible for intermediate and depot level diagnostics and ATE systems software.

Table 3-1: Maintainer Responsibilities for Software

The EW systems management community has an especially clear view of the interrelationships between these various roles. They see the players in the flow of maintaining EW systems as encompassing all of the following:

- Intelligence community - provides new threat data from the operational environment.
- Operational units - provides operational requirements based on mission accomplishment and newly-received threat data.
- Tactical Air Warfare Center (TAWC) - provides operational requirements based on mission accomplishment and newly-received threat data.
- System Program Managers - provides system requirements to perform system upgrades. These requirements are reported to come from users in the field, generated from intelligence data by the TAWC or generated by the ALC itself.
- Air Logistics Center - performs engineering efforts necessary to make modification, test modification, and document and use depot resources to prepare for shipment to the field, as shown in Figure 3-1.
- Organizational and Intermediate maintainers - install modifications into systems and maintain systems.

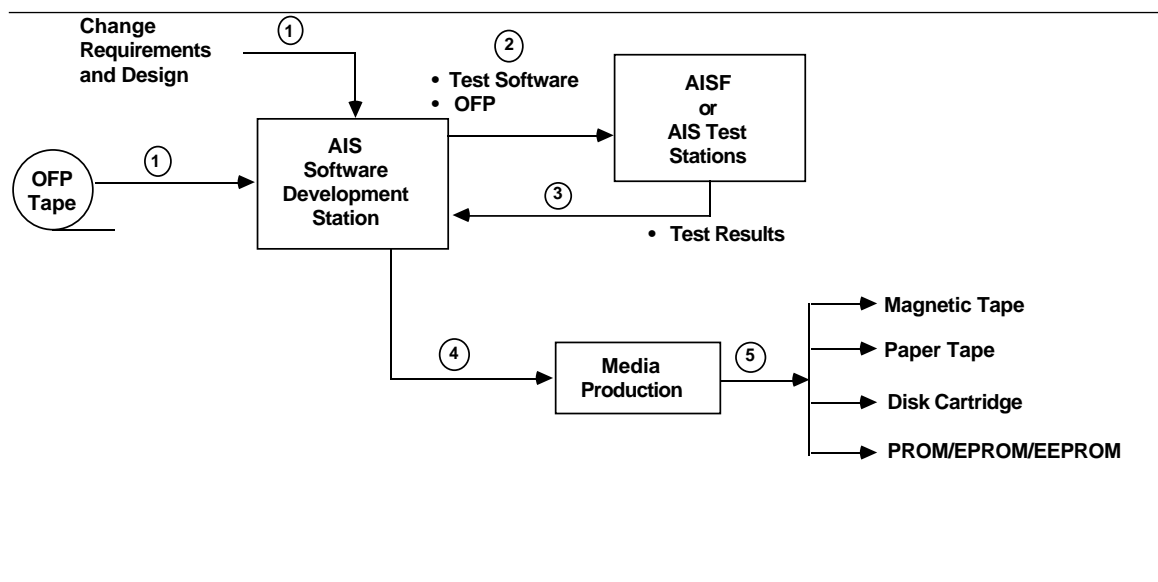

Figure 3-1: ALC Efforts in AISF and Software Support Centers

For these reasons, the issues identified by participants in these discussions and listed below tend to address not only software, but also the processes of acquiring, developing and maintaining software-intensive systems. These issues also have impacts on other areas. For example, in the area of documentation, the decision to reduce the numbers of deliverable documents and the expected contents of these documents as means of managing cost and schedule (without adequately controlling the underlying process) may have impacts evidenced by poorer software development quality, greater post deployment software support costs and greater difficulties in adequately testing the system. This is why it is so important that the acquisition personnel who are

overseeing systems development and delivery also need to be educated as to software's life cycle needs. No matter how well educated the contractors are, it may not make enough difference unless program managers make PDSS concerns a priority in the acquisition.

3.2. Acquisition Issues

Certain individuals participating in the fact-finding discussions felt that more acquisition problems were at the managerial level than at the technical level. They felt that educating acquisition personnel only solves part of the problem. They suggested that although the DoD has the most technologically complex systems, there are not enough credible, technically competent people in the government working in the acquisition arena. *The example cited here was that technical oversight is often tasked too far down within the acquisition organizations, primarily because there are too few people in the acquisition offices and too great a workload for these people to handle.*

Participants at all locations felt that acquisition personnel need to do a better job of specifying the software systems, tailoring the procurement (including requirements and reference documents), and then enforcing compliance with the requirements as written. They felt that it is necessary for acquisition personnel to understand the processes that they are responsible for managing. This was pointed out several times during discussions that too often cost and schedule needs drive changes which are made by cutting documents or contents, rather than better controlling the development process. One point made was that documents should not be thought of as separate products, but as an integral part of the engineering efforts. Another viewpoint expressed during these discussions is that, although acquisition personnel are driven by cost, schedule and performance issues, they need to be convinced that the standardized formats specified by the Data Item Descriptions (DID) should be adhered to. Eventually, all the documentation produced by the prime contractors and the sub-tier contractors gets turned over to the ALCs for support of the systems. Depot-level maintainers reported that advances like MIL-STD-1840, Initial Graphic Exchange Specification (IGES), Standard Generalized Markup Language (SGML) and other efforts, such as Computer-Aided Acquisition and Logistics Support (CALS), will indeed be useful. Depot personnel believe the weapon system software development process represented by DoD-STD-2167 to be a comprehensive and robust process when the design and documentation are built first and detailed design and code follows.

It was felt that the acquisition community does not have the best tools available to support acquisition efforts in both the planning and documentation aspects. The acquisition community needs to have an available library that will support building a cohesive and comprehensive contract, statement of work, and functional requirements. The problem is identifying what the system and the software must do and then ensuring that the proper standards, specifications and deliverables are included in the contract. This may be a future action for Headquarters, Air Force Systems Command, to take the lead in establishing such an entity, with inputs coming from all levels of system responsibility (i.e., using commands, ALCs, AFALC, SPOs and contractors). The INQUIRE system being developed under the Policy and Procedure Guidance Project of the Computer Resource Management Technology Program (PE64740F) is a start towards these

kinds of tools. These tools could augment the abilities of the acquisition personnel. The feeling of some participants was that these tools are especially needed since there are too few technically literate individuals in the acquisition process. For example, in the B-1B procurements, the omission of one word in a particular contract (as compared to another contract for another system which had to function with this system) is reported to have changed the test philosophy for one of the major contractors. Part of the aircraft systems have been designed to "detect and isolate failures on the aircraft while in flight", while other on-board systems were designed to "detect failure in flight and fault isolate on the ground."

Not only do acquisition personnel need to understand acquisition issues, participants commented that acquisition personnel must personally understand the processes that they are responsible for procuring, i.e., the operational aspects of the systems, instead of relying solely upon inputs from the user. The Ogden ALC reports substantial benefits have been achieved through the use of operational personnel from the co-located TAC wing in cooperation with the developers. These efforts have used the test stations and integration facilities to coordinate and evaluate proposed changes to the pilot-machine interface. Participants strongly felt that there needs to be a more effective use of DO personnel in development efforts as part of a co-located team, rather than having to fly operators and pilots in from operating locations. The importance of early involvement by operational personnel was repeatedly stressed since it is too late to make a cost-effective impact on system development by the time the acquisition has reached its Preliminary Design Review or Critical Design Review.

Acquisition personnel (Program Managers and Deputy Program Managers for Logistics (DPML)) need to get the ALC/MM involved earlier in the program life cycle. Typically, the DPMLs are overworked, and the ALCs have the insight into and the experience with PDSS issues. The suggestion was made that all DPMLs work at an ALC for a three year training assignment before moving into their first DPML assignment. The 96th BMW reports that they have successfully integrated the Oklahoma City ALC into certain of their working group meetings.

It is felt, however, that program managers are typically not rewarded for really caring about the quality of maintenance. *Within the current DoD acquisition and personnel management schemas, there is no way to reward the program managers for the quality of software maintenance (or any other maintenance) of fielded systems.* Their greatest concern is to get the system built on time and within budget. The major drivers, in order of importance, often appear to be: cost/schedule, performance, usability, then supportability. Program managers are primarily rewarded only for meeting schedule and budget requirements of his project; thus, the support aspect in general is the first to be cut or ignored. In addition, it was expressed that the inclusion of maintenance aids is often viewed by upper levels of management as "gold plating." However, the opposite is true. While these aids may cost more in the short term (in the system's acquisition), they can ultimately reduce system life cycle costs in the long term.

Several participants in these discussion felt that there needs to be a single responsible focal point for software during the development of a system. *It was suggested that each program office have a designated Deputy Program Manager for Software (DPMS) who would be responsible for the software portion of the acquisition program, much as the DPML is responsible for the logistics*

portion. A responsibility of the DPMS would be to increase the emphasis placed on software evaluation of characteristics such as software testability and software maintainability. They felt that the functionality of software is currently addressed by other test efforts, but the evaluation of the software and its supporting documentation to meet PDSS needs is not currently given as much emphasis. They was suggested that these efforts be incorporated as part of the formal test process under the cognizance of the DPMS. Regardless of how the idea of a DPMS is viewed, it was agreed that the Air Force must adopt a systems approach to acquisition, but with a software emphasis.

In addition, an infrastructure consisting of training, courses, schools, and distinct career paths for software acquisition personnel does not exist. The data processing (or information management) training provided to an Information Systems (AFSC 49XX) officer is often felt to be inadequate as preparation for dealing with hard real-time embedded computer systems. Several participants felt that we have too few technically literate people in the acquisition process. The need is not necessarily for experts, but for individuals who are technically literate in the entire software life cycle, including PDSS.

Acquisition of the systems needs to be better coordinated according to participants. In the case of the ALR-69 radar warning system for the F-4 and F-16 fighters described to the fact-finding team, the hardware boxes were reported to have arrived at the squadrons before the test stands and technical orders. Once systems such as these arrive at the squadrons, technical order changes arrive through the standard technical order distribution officer (TODO) channels, but software changes arrive through other maintenance channels. Thus, there is often an incompatibility between the fielded software and the documentation. In another instance, TAC is reported to have asked the ALC to delay releasing a block change to an aircraft OFP because of the impact caused by retraining for the modified pilot-machine interface. The B-1B maintenance training sets (a Systems Maintenance Training Set and a Avionics/Armament Maintenance Training Set) are reportedly not consistent with the configuration baseline of the aircraft. The training sets are at Baseline 2, while the aircraft has moved past Baseline 30. Participants did not attempt to assign fault in these areas, either to operational commands, program offices, or to contractors. Instead, they felt that the problems were indicative of a general tendency to look first at hardware, then software and finally, at support for the systems. Participants suggested that there needs to be a single installation date for any new system, when the system, supporting equipment and documentation, test equipment, software models, software and hardware maintenance capabilities and the mission data generation capabilities are all available at one time for all the parties involved. There was also an awareness that perhaps this procurement model would unnecessarily delay fielding of mission-critical systems while they waited for support systems to catch up.

A related issue is that the operating commands typically have not established a central program management office. For example, the Deputy Commander for Operations (DO) is responsible for simulators, but the Deputy for Logistics (LG) is responsible for test sets. A central office would provide a focus for people to take a weapon system perspective and manage the evolution of the system in a top-down, integrated fashion. Early establishment of such a program management office would allow using command participation earlier in the development efforts, as suggested above.

3.3. Post Deployment Software Support Issues

One participant estimated that sixty to seventy percent of the life cycle costs for a software-intensive system are found in post deployment software support (PDSS). PDSS is the sum of all activities required to ensure that, during the production/deployment phase of a mission-critical computer system's life, the implementation and fielded software/system continues to support its original operational mission and subsequent mission modifications and product improvement efforts. *Several participants in our discussions felt that altogether too often, when life cycle costs are addressed, the majority of the attention is being focused on up-front hardware costs, effectively delaying software costs into the PDSS.* During the discussions at Hill AFB, Mr. Bruce Rudd briefed the OO-ALC/MMEC position on PDSS issues. This briefing is found in Appendix C.

One concern raised by participants deals with the contractor's perspective towards PDSS. Currently, contractors willingly sell manhours to support fielded systems that they developed or helped to develop. In fact, it was felt that contractors may, knowingly or unknowingly, allow this to affect the quality of their efforts during system development. *However, some maintainers reported concerns that in today's business world with shortages of key, talented personnel, contractors may be forced or choose to put all or most of their efforts into major new programs, like the Advanced Tactical Fighter, effectively reducing the supportability of current weapon systems which have depended on procuring continuing contractor support.*

Documentation is considered to be a common problem. Depots report receiving documentation that has been written directly from the completed code. The concern here is that it is difficult to get software designers to document their efforts. This is not necessarily true because of some personality failure of software designers, but that the tools to easily allow capturing the design data and design decisions are not readily available in the domain in which they normally work. It was felt that a hardware design lends itself to being documented on paper, but that a software design needs to have a way of being captured electronically while the software engineer works at the terminal. Participants agreed that this can be a major cost driver; however, sound documentation principles should not be minimized. In-house ALC software efforts stress documentation at all levels of the development. The use of Ada® was highly stressed as an aid to the documentation problems. This does not imply that Ada itself is self documenting, but the use of the language lends itself to documentation "as-you-go."

Deliverable documentation must be traceable and useful for PDSS personnel. Different numbering schemes for requirements, design, code and test cases and data invariably lead to confusion and additional effort to correctly cross-reference these items. The software maintainer's greatest difficulties are in finding "where something exists." This may be anything from a simple parameter to a specific embedded function or a function performed in the code or documentation. An additional problem cited is the emergence of flawed "boilerplate" text. This text may be incorrect or it may be a meaningless standard prologue (or "blurb") that gets copied everywhere with only the name of the module changing. Standardization would be less of a problem if methods such as IGES or SGML were employed during software development phases of the system life cycle.

3.4. Software Development Issues

A consistent software design methodology needs to be applied throughout the system development for all related components of a system. For the B-1B Central Integrated Test System (CITS) (shown in Figure 3-2), a matrix was attempted that would show the compatibility of the various software-intensive systems based on these attributes:

- programming language
- coding standards
- design philosophy/methodology
- CITS philosophy
- CITS tools

In many cases, the compatibility of these programs or versions of programs was found to be less than complete or unknown.

Generally accepted software engineering principles need to be applied to the development of line replaceable units (LRU) — the black boxes. Often the software that is hidden inside these boxes is not developed by a software-oriented engineer, but by electrical engineers, mechanical engineers or aeronautical engineers; all of whom tend to be hardware-oriented. These boxes (and their associated software) have to be maintained over the entire life time of the weapon system; thus, it was suggested that more influence by software specialists would greatly improve the quality of software.

Participants suggested that greater attention on the issues of software usability and software maintainability needs to occur during software development. Issues such as operability, "user friendliness" and response time need to be substantively addressed as the system is developing. *Also needing consideration is the area of software security and the operations impact that secure computing has.* For example, the B-1B has eight primary computers and its data cartridges must be removed and replaced by a maintainer. The Strategic Mission Data Planning System (SMDPS) data cartridges provided to the B-1B aircraft (as shown in Figure 3-2) can contain highly classified data.

Mission data must also be maintained over the lifetime of the system. Participants felt that this area was often not well understood or addressed in the design of complex systems. It was felt that operational software must be designed with a clear separation between the algorithmically-oriented operational flight programs (OFP) and the mission data, as shown in Figure 3-3. The mission data tends to be more volatile than the OFP, and is not necessarily "just" a few parameters that can easily be hardcoded into the software. In the EW Avionics Integrated Support Facility (EWAISF), the team members were shown a set of mission data parameters for a particular radar warning receiver. This collection of controlled, classified data was best measured in terms of inches of hardcopy, rather than as numbers of parameters. The magnitude of these kinds of changes are best understood in light of an example of a particular EW system described at WR-ALC. A particular change in the unit required replacing soldered PROMs on over 20 printed circuit boards in approximately 2000 fielded units. In addition to the logistical issues in distributing these changes, there are also reliability and maintainability issues to be considered.

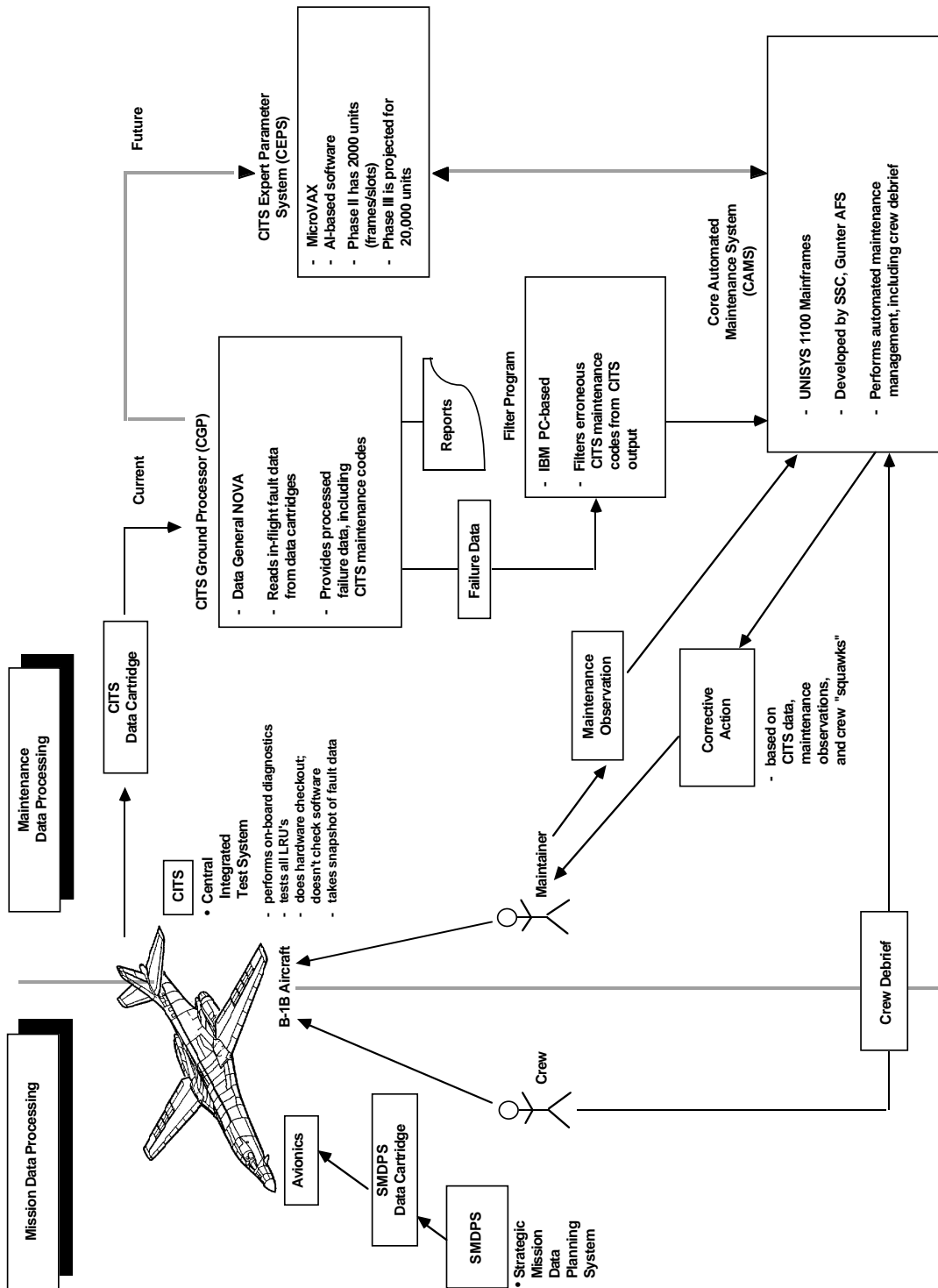

Figure 3-2: Planned Approach to B-1B Data Processing

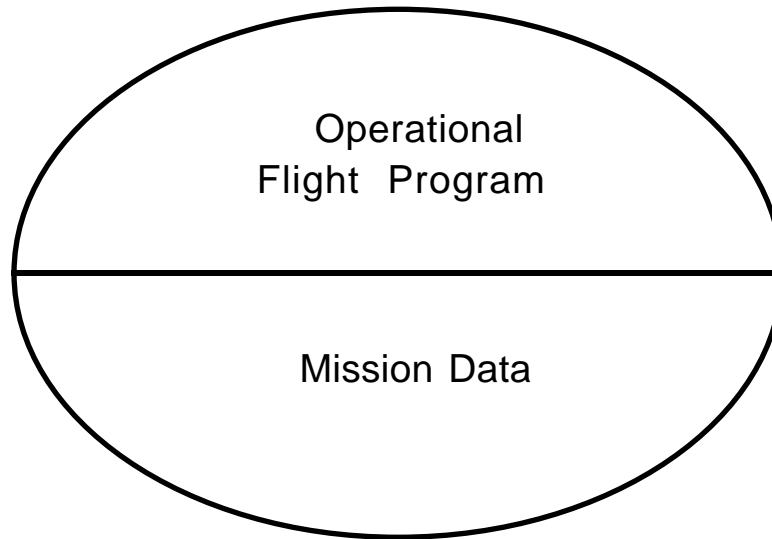

Figure 3-3: Desired Separation of OFP and Mission Data

In addition, a common Air Force software integration laboratory or environment is not currently available. The B-1B Program Office was forced into assuming the role of system integrator, due to funding constraints which prevented paying a contractor to perform this role. Due to this, the government has had to accept the products of numerous development environments and then integrate the weapon system. In the B-1B environment, this has led to the establishment of the CITS Maturation team. This group of six officers and senior NCOs is functioning in an integration and trouble-shooting role. The original planned approach for CITS maintenance data processing is already showing signs of change. The CITS Expert Parameter System (CEPS), an AI-based expert system currently being developed, and the Filter Program are additions to the overall system shown in Figure 3-2.

Also impacting the B-1B maintenance efforts is the Core Automated Maintenance System (CAMS), shown in Figure 3-2. CAMS is being developed by the Air Force Standard Systems Center, Gunter AFS, under a Program Management Directive from HQ USAF/LEY. It is a common Air Force-wide system replacing comparable systems that used to exist at the major commands. Its implementation is being driven by the planned CAMS schedule. Previous releases of CAMS have had failings. Fixes are being promised in future releases and are not being released separately, but are being incorporated into the next scheduled release. The next release has currently had four scheduled delivery dates. Problems with this system have been receiving senior management attention.² HQ SAC requested that the CAMS baseline be frozen and solidified (i.e., made to work) before proceeding with enhancements. User's suggested enhancements or fixes appear to be at least a year away from reaching the field, while errors in the CAMS

²Message 031834Z Aug 87, HQ SAC to SSC Gunter/CC (Commanding Officer) with copy to SSC Gunter/AQM, Subject: Accelerated Fix of Critical CAMS Problems

system are causing the loss of maintenance records totaling five to six thousand man hours per month. The 96th BMW has reportedly lost records for over 31,000 man hours of B-1B maintenance actions. The fix to resolve this is reported to be a one line code change, but it has not yet been distributed, as the next release is not ready for distribution.

The current testing practices, including independent validation and verification (IV&V) based on sampling, are reported by participants as leaving much to be desired in today's integrated environment. *All-up end-to-end system testing, though expensive, is necessary to insure operability of the complete weapon system.* It was suggested that Program Managers need to understand that IV&V funds are not a negotiable item. These efforts are important, but costly.

3.5. Supportability and Testability Issues

It was commonly reported that system design to support testability is often lacking, in the view of organizational maintainers. Built in test (BIT) often fault isolates at too high a level — identifying multiple LRUs as faulty — effectively forcing the technician to "shotgun" replace an entire ambiguity group in order to return the aircraft to a ready state. This situation is especially true in multiple failure situations, where the probable cause of failure identified by the test station or BIT is not adequate. Often in these cases, there are also not enough test points to be able to meet the acquisition requirements regarding fault isolation to a single replaceable unit within a given probability.

It was felt that Integrated Diagnostics is not getting the attention up front in the systems life cycle that it should. It was acknowledged that functional requirements (i.e, fly the aircraft) get the attention during acquisition. On the other hand, BIT doesn't fly the airplane and designing for testability generally adds to the development costs.

The Air Force is pursuing currently a five year development effort with ten contractors involved in this area to develop a Generic Integrated Maintenance Diagnostics System (GIMADS). Participants felt that a common strategy or a standard for maintenance software is needed, but that the pressure to use off-the-shelf components (as in the mandate to maximize use of F-16 components in the B-1B) could limit the effectiveness of such an approach.

A problem which has been magnified by software, rather than reduced, is the "Could Not Duplicate" (CND) class of failures. These reportedly account for approximately twenty to thirty percent of all failures received in the shops. In order to keep adequate spares on hand to keep the aircraft flying while CND boxes are checked out unnecessarily, additional inventory is brought into the logistics channels. For one system alone, this accounted for over a million dollars in spares. Another system was reported to have required an expenditure of 7.42 million dollars for a set of eleven black boxes. The maintainer's ideal state is to have a system that delivers a high mean time between failures and a low CND count. A program undertaken at Hill AFB to address this problem is the "Bad Actor" program. LRUs which have failed twice on the aircraft, but have passed tests at the intermediate shop, are sent directly to the prime ALC's Engineering Division. This bypasses the depot level intermediate shop, which uses the same test sets and test software as the intermediate shop at the wing. While this process flow is valid, efforts should insure that

depot level maintenance personnel be directly involved in the programs that they have the greatest combination of historical and experience base in identifying problem areas.

From comments made by the participants, it appears that the SPOs need a better understanding of the need for competent technical oversight, and that they should plan for at least ten percent of the acquisition resources dedicated to IV&V. The concern here is twofold. First, there often is a perception that there is not enough technical expertise in the SPOs to know if the support being acquired is sufficient and useful to the maintenance community. Secondly, there are concerns about the development and retention of some "corporate knowledge" about the system. It was felt that individual engineers develop competencies about the system under development, but that this knowledge may not necessarily remain in the program offices as personnel transfer out. For these reasons, it was suggested that the acquiring command might "contract" this effort out, either within the service to an ALC or outside the service to an appropriate contractor — either a contractor or a federally-funded research and development center.

3.6. Personnel Management Issues

Personnel management and assignment/rotation issues surfaced in several of the discussions. *Maintainers report that from their perspectives the acquisition personnel repeatedly make the same mistakes, but also that every contact with the SPO is always with new people.* Other concerns mentioned dealt with the lack of experienced people in acquisition offices, especially experienced logisticians. As mentioned in Section 3.2, it was suggested that all DPMLs work at an ALC for a three year training assignment before moving into their first DPML assignment with Air Force Acquisition Logistics Center (AFALC).

Personnel concerns were heard repeatedly in the discussions at the ALCs. Most of the organizations had a considerable concentration of hardware engineers, mostly electrical engineers, with some other engineering disciplines represented. In general, there were few computer scientists represented within the engineering population. This was reportedly attributable to the civilian personnel management practices that required all engineers (even those filling software engineering-related positions) to have completed a certain number of course units in the traditional engineering disciplines — courses that may not be part of a typical computer science curriculum.

The impact of these personnel management policies is felt within the AFLC as it adapts to meet increasing requirements to maintain and modify software. The EW Management Division at Warner Robins showed the team electronic warfare pods that required changes and modifications by:

- Removing and replacing hardware circuit cards in a shop
- Adjusting potentiometer settings on circuit cards in a shop
- Removing and replacing memory cards in a shop
- Reprogramming memory while the pod is mounted on the aircraft using a memory loader/verifier

These EW pods have progressed from being a strictly hardware device to units containing ten or more microprocessors, each with its own OFP. *As these systems evolve with increasing functionality through increased software capability, a corresponding increase in software capability is required within the personnel of the Air Logistics Centers.* This capability was characterized by one manager as being necessarily organic within the ALC, and as requiring higher skill levels.

While needing more highly skilled individuals, managers report that they have experienced high attrition among the journeyman-level engineers. These rates were reported to have been as high as 18 per cent attrition annually among GS-12 engineers. Approximately half of those leaving reportedly left as a result of lack of professional or monetary progression, or due to salary imbalances between government and industry. The GS-12 level engineer is reportedly stifled by a lack of progression since the engineer must either stay at GS-12 or move into supervisory and management positions.

Another issue raised was the perceived low self esteem of many government employees. This is best evidenced by the old saying, "It's good enough for government work." People don't necessarily want to do work that is just "good enough," but that may be all that they are able to do with the available resources. One organization visited was authorized over ten per cent more personnel than they had been appropriated budget for, and, in addition, currently had almost another ten per cent of their positions vacant awaiting hiring actions. This same organization is responsible for maintaining one hundred and seventy-five systems with over 4500 software programs. Of these programs, about 320 are modified each year and approximately one hundred and fifty new programs are written each year. Not only are there over 4500 software programs that this organization is responsible for, but these programs account for 58 different languages and systems software packages on over 50 different computers. This proliferation of programs, languages, and computer systems dictates the need for a large, technically competent work force.

The real problem, as perceived by some managers, is "inflexibility." *They feel the need to have flexibility in getting the people and the resources that they need, based on some economic justification, much more like a business is managed.* The perceived reality of managing within the acquisition and maintenance communities is not, "Who can I best get to do this job?" but, "What did I get?". Managers report that they need to be made accountable for their efforts, and then given the tools and responsibility to see that the job is competently performed within cost and schedule constraints. The desire to do the job, and to do it properly, is evident, but the resources to do this may not be available within an environment which limits the number of people who may be hired.

4. Recommendations

4.1. Software Blue Two Visit Messages

Historically, software is one area that has not been as well understood during weapon system development as, perhaps, it should have been. Whereas hardware aspects are now being redefined and understood, software programming functions have always been viewed as an "in the closet" operation — where the programmer was often left alone to magically develop a logical structure which eventually went to satisfy the requirement. Thus in most of the earlier weapon system programs, little or no emphasis was given to the functionality, supportability and consequently, the usefulness of the software until the system was turned over to the using command. Today there is an increasing effort within DoD to correct these past indifferences and turn attention not only to hardware reliability and maintainability but also to the critical aspects of software.

However, to effectively change present attitudes, the approach must go beyond improving and streamlining of the acquisition process — it must be a conscientious effort on the part of government and industry to scrutinize the environment in which software is developed and maintained so that critical support issues are identified and dealt with.

This section summarizes these critical messages from Air Force maintainers to industry's software development community that the AFCOLR Software BTV fact-finding Team heard in their visits to the various Air Force units.

Suggested areas of focus for a software-oriented BTV included:

- operational flight program software
- avionics operational flight program software
- built in test within the overall scope of operational flight program software
- SAC, TAC and ALC mission areas
- EW operational flight program software
- PDSS maintainers
- software users (operational issues)
- software maintainers (maintenance and PDSS issues)
- automatic test equipment software
- Integrated Diagnostics
- C³I software
- software support environments (SSE)

Within these focus areas there are relevant issues that relate to:

- system orientation
- acquisition/support policies and practices

- post deployment software support
 - Documentation
- software development
 - integration
 - interoperability
 - compatibility
- supportability and testability
- maintainability
- commonality
 - between weapon systems (aircraft)
 - between sub-systems (RADAR, EW, communications, etc.)
 - between ATE modules (intermediate and depot level congruence)
- personnel management

Not only did the fact-finding team hear messages that could be conveyed to contractors, but the team also heard suggestions that an Air Force "Tiger Team" be staffed and empowered to resolve issues in these areas. The suggested emphasis would be on providing solutions to PDSS issues, not simply airing these issues to contractors as with the BTVs. Suggested tasks for a tiger team include tasks relating to speeding the widespread use of reusable software components:

- identification of reusable software components
- redevelopment of these components in Ada
- coordination of efforts dealing with reusable software components, including the development of a standard DoD database of reusable software components providing a means to search and extract from this database based on keywords, abstracts, or specifications of the software "components" contained within the library
- demonstration of benefits of standard software components using Ada
- development of military specifications for software components defining form, fit and function, much as is done for hardware components today

4.2. Communicating the Software Messages

This section attempts to define how these messages can best be communicated to industrial designers and managers and government acquisition personnel. As illustrated in Figure 4-1, the software inventory of the U.S. Air Force is fairly diverse. The discussions held as part of this BTV fact-finding process focused on the issues relating primarily to weapon system software for Air Force aircraft.

The conclusions that emerged from the various discussions were that the messages of a general, software-oriented BTV should not be limited to just radar, electronic warfare, or any other single

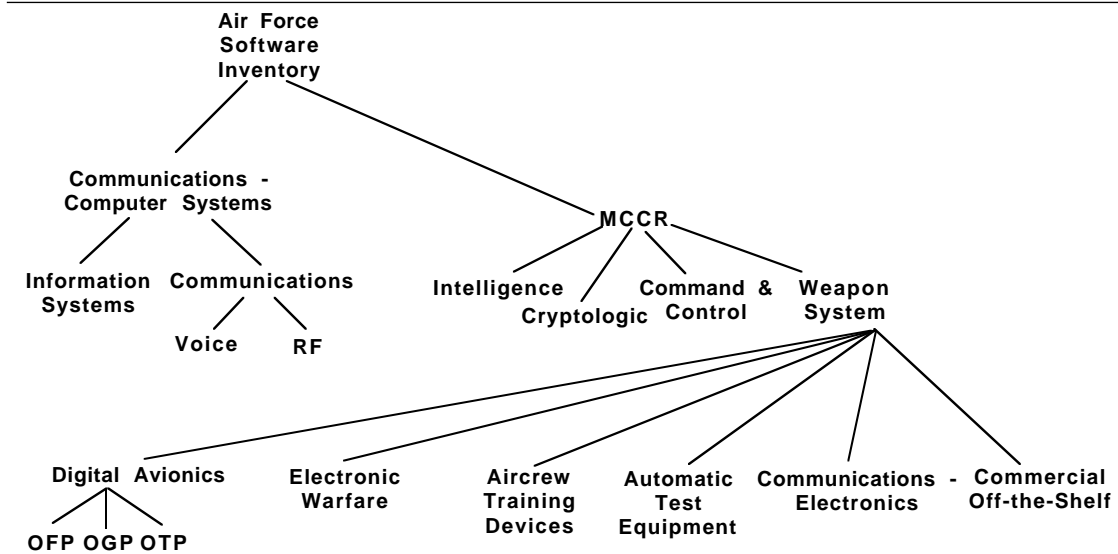

Figure 4-1: U.S. Air Force Software Inventory (adapted from AF and AFLC Regulations)

aspect of avionics. They should also not be limited to just one operational viewpoint. The trip should involve exposure to SAC and TAC as well as the ALCs. Many participants noted that although a general BTV on software would be useful, a specific BTV, targeted at issues in any one of the categories of software shown in Figure 4-1, would also be extremely useful to an industry audience familiar with that category of software systems.

In general, software-oriented personnel who met with the fact-finding team were supportive of the concept of a software-oriented BTV, providing the BTV was oriented to show real issues and problems such as poor documentation or ill-defined interfaces along with effort necessary to correct these problems. It was suggested that software-oriented BTV participants get a chance to actually see fault isolation tasks performed, and then to visit the intermediate avionics shops. It was also suggested that perhaps a unit such as the 419th Tactical Fighter Wing, an Air Force Reserve unit, could be used for some of the "hands on" tours, because a BTV would impose a lesser impact on mission performance on this unit than on an Active squadron.

A facility such as the F-16 Avionics Integration Support Facility (AISF) could be used to demonstrate the mission of the ALC. This facility represents the expenditure of over thirty million dollars of AFSC computer funds, with over 130 organic plus 90 contract personnel manning the facility. Its purpose is to provide an organic weapon system change capability. The AISF must provide integrated hardware and software avionics support that is both responsive to changing mission needs and is cost effective. The role of the AISF is illustrated in Figure 4-2. The AISF contains extensive computing resources. For the F-16 A/B, it includes a DECsystem-10™, VAX™-11/785,

and an Evans & Sutherland PS 2™. A separate heads-up display test station includes a functional heads-up display, while the Dynamic System Simulator includes a functional cockpit mockup with seat, sticks and displays. The F-16 C/D configuration will contain an IBM® 4381 central processor.

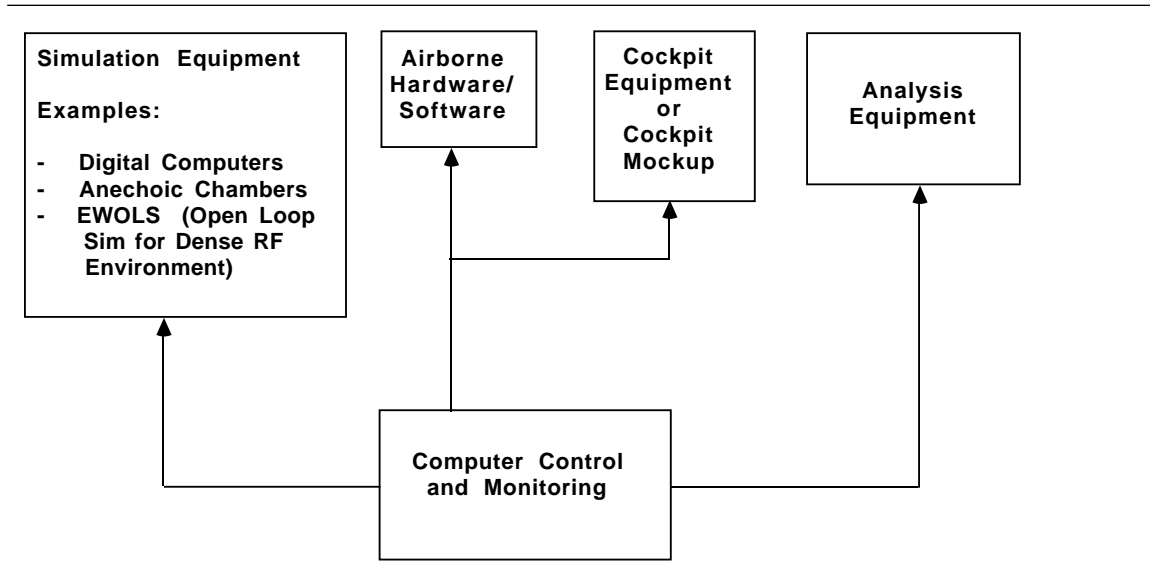

Figure 4-2: Components of a Typical Avionics Integration Support Facility (AISF)

A potential EW software BTV could travel to Eglin AFB to meet with F-15 users and maintainers at both the 33rd Tactical Fighter Wing and the Tactical Air Warfare Center, before traveling on to Langley or Shaw as other operational sites. Seymour Johnson was also mentioned as a possible operational site, because it has the newest version of the ALQ-131 pod on their F-16s. Any EW software trip could conclude at Warner Robins Air Logistics Center and the EWAISF.

Visits to organizations where software use is the primary means of mission accomplishment, such as Space Command at Falcon AFS, Global Weather Central or the AWACS (E-3) at Tinker AFB, were also suggested. The 552nd Airborne Warning and Control Wing at Tinker AFB was suggested because of their role in aircraft software maintenance and simulation for testing.

4.3. Targeting the Message

This section enumerates the various groups of personnel who may be candidates for participating in a software-oriented BTV. It would be beneficial to involve both senior-level technical personnel, as well as senior management, in a software-oriented BTV. It was also suggested that Air Force program management personnel be involved in this BTV.

Key personnel who would benefit from the exposure offered by a software-oriented BTV are in the following categories:

- Program Managers
- Directors or Managers of Software Engineering
- Systems Engineers
- Software Engineers
- Design Engineers
- Logistics Engineers (Test Stations, Test Software, Test Program Sets)
- Human Factors Engineers
- Software Quality Assurance Engineers
- Systems Integrators
- Acquisition personnel from Air Force Systems Command and other major commands
 - System Program Office Directors
 - System Program Office personnel (e.g., ASD/EN or EA)
- Operating personnel, specifically pilots to expose them to the realities of complex software maintenance actions

4.4. Identifying the Software Blue Two Visit

The question, "What should the Software BTV be called?" is important in communicating the focus and target of a software-oriented BTV to decision makers in order to attract an appropriate cadre of people for the BTV.

Several names for software-oriented BTVs were suggested throughout the discussions at the various units. These include:

- Aircraft Operational & Test Software BTV
- Aircraft MCCR Software BTV
- Avionics Operational & Test Software BTV
- Avionics PDSS BTV
- Aircraft Software Supportability BTV
- Aircraft Software Operations and Test Supportability BTV
- Aircraft Software "ilities" BTV

- Aircraft Software: Usability and Maintainability BTV
- Aircraft Integrated Software BTV
- Aircraft Integrated Software Support BTV
- Integrated Aircraft Software Support BTV
- PDSS BTV
- Software Support BTV
- Electronic Warfare Software BTV
- Software (topic) BTV - with "topic" being your choice of: avionics, EW, etc.

A consensus was reached that the best name for this BTV was Aircraft Operational and Test Software BTV.

5. Conclusion

The fact-finding team, based on information gathered from discussions, has attempted to summarize from a maintainer's perspective, the issues which ultimately decide supportability of software for a weapon system. As reported, these issues play a major role in determining the quality of maintenance and life cycle costs:

- weapon system orientation
- acquisition
- software development
- post deployment software support
- personnel management

These findings, although specifically intended to define the scope, message, and target audience for a software-oriented BTV, should also serve as indicators to Air Force program managers in understanding the approaches that must be taken to improve the current acquisition and support processes.

From the activities visited, it is apparent that there are messages from software maintainers and users to industry and government, and that software with its associated reliability and maintainability concerns is a candidate for BTV exposure. It is the team's consensus that these concerns within each of the Air Force's software resources (shown in Figure 4-1) are deserving of management attention through one platform or another. However, the BTV priority should be given to those resources with the greatest impact on combat capability and national defense, such as critical weapon system resources. Problems in supporting these systems degrades the ability of the Air Force to meet its mission; thus, a "show and tell" platform is key in elevating the software maintainer's concerns to the decision maker level.

Before conducting a software-oriented BTV, there are some distinctions between the hardware and software environments that must be understood. This is due, for the most part, to the obvious differences in the nature of the two; hardware deals with visible, tangible entities, and software addresses logical structures and complex processes.

However, the most significant distinction noted by the team in terms of presenting software within the BTV platform is the contrast of constraints underlying maintenance of hardware and software. The flight line environment typical of a BTV serves to communicate the realistic conditions under which the maintenance of hardware must be performed. The cold weather, the open hanger, the lack of spare parts, and the use of special support gear effectively highlight to industry the day-to-day constraints of maintenance and the necessity for future reliable and maintainable weapon system components and support structures. In the software environment, the "constraints" are largely due to the combination of technical and management variables which are in place as a result of the system — the way the Air Force currently does business. These factors can be changed. The fact that the ALCs do not have adequate computer support and support tools is not a "real world" limitation like the freezing weather in Minot, ND, or maintaining an aircraft while in chemical/biological/radiological gear. Thus, care must be taken not to present to industry a

look at unrealistic limitations; and although these variables are valid in describing the maintainer's inability to perform the job, one cannot assume that the same limitations apply as with hardware.

The intersection of the two environments centers around two main issues:

- the impact of a hardware or software design on maintainability
- inability to adequately support these systems can determine the success or failure of the Air Force mission

As the first in a series of Blue Two Visits on weapon system software support, it is recommended that the visit focus on BIT/ATE or EW software. These subjects take advantage of the overlap of environments and will make it easier to transition the target audience from what appears to be purely hardware to the ultimate software driver and underlying support issues. It is these issues that are the concerns of the software maintainers. In the BIT/ATE arena, the lack of sufficient test points translates to more CNDs, more spares on hand, and more cost to the government. In the EW arena, the inability to do rapid reprogramming is costing the government in terms of weapon system readiness. If not properly focussed upon, this issue alone could present a voluntary choke point in a wartime theater.

For BIT/ATE concerns, Dyess AFB (96th BMW), Hill AFB (388th TFW/OO-ALC), and Robins AFB (WR-ALC/MAI) are all candidate locations. For a software BTV oriented at EW concerns, Robins AFB (WR-ALC/MMR), Eglin AFB (TAWC), and Shaw AFB (363rd TFW/MA) are recommended as candidate locations.

In terms of the target audience, attentions should particularly be given to the Air Force acquisition community. As participants repeatedly pointed out, many problems appear to stem from:

- a lack of "life cycle" consciousness on the part of government program managers
- a failing of system program offices to fully assess the importance of software support
- a lack of understanding of the impact software has on combat capability and weapon system readiness.

To achieve the greatest benefit with the software BTVs, participation must include representatives of major system acquisitions.

Lastly, to minimize the impact on planned BTV efforts described in Section 1, it is recommended that the software BTV be conducted in May 1988. This is necessary to allow for adequate pre-site planning needed to ensure effective "hands-on" demonstrations and dialogue.

Appendix A: List of Acronyms and Office Symbols

AAC	Alaskan Air Command
AF	Air Force
AFALC	Air Force Acquisition Logistics Center
AFB	Air Force Base
AFCOLR	Air Force Coordinating Office for Logistics Research
/MEI	HQ USAF, AFCOLR, Maintenance and Engineering Division, Independent Research & Development, Blue Two Visit Program (<i>office symbol</i>)
/XRI	HQ USAF, AFCOLR, Plans & Programs Division, Information Systems Branch (<i>office symbol</i>)
AFLC	Air Force Logistics Command
AFOTEC	Air Force Operational Test and Evaluation Center
AFRES	Air Force Reserve
AFS	Air Force Station
AFSC	Air Force Specialty Code, Air Force Systems Command
AGS	Aircraft Generation Squadron
AI	Artificial intelligence
AIS	Avionics Intermediate Shop
AISF	Avionics Integration Support Facility
ALC	Air Logistics Center
ARC	Area Reprogramming Capability
ASD	Aeronautical Systems Division
/RWA	Inter-Command Electronic Warfare Management Directorate (ICEWMD) (<i>functional office symbol</i>)
ATE	Automatic Test Equipment
ATF	Advanced Tactical Fighter
AWACS	Airborne Warning and Control System
BIT	Built In Test
BMW	Bombardment Wing
BTV	Blue Two Visit
C ³ I	Command, control, communications and intelligence
CALS	Computer-Aided Acquisition and Logistics Support
CAMS	Core Automated Maintenance System
CASE	Computer Aided Software Engineering
CEPS	CITS Expert Parameter System
CITS	Central Integrated Test System
CND	Could Not Duplicate
CRS	Component Repair Squadron
DID	Data Item Description
DO	Deputy for Operations (<i>office symbol</i>)
DoD	Department of Defense
DoD-STD	Department of Defense Standard
DPML	Deputy Program Manager for Logistics
DPMS	Deputy Program Manager for Software
EW	Electronic Warfare
EWAISF	Electronic Warfare Avionics Integration Support Facility
FOT & E	Follow-on Operational Test and Evaluation
GIMADS	Generic Integrated Maintenance Diagnostics System
HQ	Headquarters
HUD	Heads Up Display
ICEWMD	Inter-Command Electronic Warfare Management Directorate
IGES	Initial Graphic Exchange Specification
IMA	Individual Mobilization Augmentee

IV & V	Independent Validation and Verification
LG	Deputy for Logistics (<i>office symbol</i>)
LGMMD	Logistics Maintenance Management Data Branch, HQ SAC (<i>office symbol</i>)
LRU	Line Replaceable Unit
MACIA	Integrated Avionics Branch, Component Repair Squadron (<i>office symbol</i>)
MAJCOM	Major Command
MAI	Airborne Electronics Division, Directorate of Maintenance (<i>WR-ALC office symbol</i>)
MAIT	Software Support Center Branch, Airborne Electronics Division, Directorate of Maintenance (<i>WR-ALC office symbol</i>)
MAITB	Radar and Space Communications Section, Software Support Center Branch, Airborne Electronics Division, Directorate of Maintenance (<i>WR-ALC office symbol</i>)
MAITBC	Countermeasures Unit, Radar and Space Communications Section, Software Support Center Branch, Airborne Electronics Division, Directorate of Maintenance (<i>WR-ALC office symbol</i>)
MAITC	Tactical Support Section, Software Support Center Branch, Airborne Electronics Division, Directorate of Maintenance (<i>WR-ALC office symbol</i>)
MAITCA	F-15 Radar Support Unit, Tactical Support Section, Software Support Center Branch, Airborne Electronics Division, Directorate of Maintenance (<i>WR-ALC office symbol</i>)
MAKTF	Software Support Center Branch, Missile and Aircraft Systems Division, Directorate of Maintenance (<i>OO-ALC office symbol</i>)
MAMC	CITS Maturation Branch, Maintenance Control Division, Deputy Commander for Maintenance (<i>office symbol</i>)
MAP	Maintenance Systems Analysis, Maintenance Control Division, Deputy Commander for Maintenance (<i>office symbol</i>)
MATE	Modular Automatic Test Equipment
MCCR	Mission Critical Computer Resources
MEI	HQ USAF, AFCOLR, Maintenance and Engineering Division, Independent Research & Development, Blue Two Visit Program (<i>office symbol</i>)
MMEC	Aircraft Computer Resources Branch, Engineering Division, Directorate of Material Management (<i>OO-ALC office symbol</i>)
MMEC	Integration Support Facility Operations Branch, Systems Engineering Division, Directorate of Material Management (<i>WR-ALC office symbol</i>)
MMECA	F-16 Fire Control/HUD OFP Development Section, Aircraft Computer Resources Branch, Engineering Division, Directorate of Material Management (<i>OO-ALC office symbol</i>)
MMECR	F-16 Radar/Stores OFP Development Section, Aircraft Computer Resources Branch, Engineering Division, Directorate of Material Management (<i>OO-ALC office symbol</i>)
MMECT	F-4 AISF Section, Aircraft Computer Resources Branch, Engineering Division, Directorate of Material Management (<i>OO-ALC office symbol</i>)
MIL-STD	Military Standard
MMR	Electronic Warfare (EW) Management Division, Directorate of Material Management (<i>WR-ALC office symbol</i>)
MMRR	Engineering and Reliability Branch, Electronic Warfare (EW) Management Division, Directorate of Material Management (<i>WR-ALC office symbol</i>)
MMRRA	Emergency Reprogramming Center, Simulation and Evaluation Section, Engineering and Reliability Branch, Electronic Warfare (EW) Management Division, Directorate of Material Management (<i>WR-ALC office symbol</i>)
MMRRC	EW Active Systems Section, Engineering and Reliability Branch, Electronic Warfare (EW) Management Division, Directorate of Material Management (<i>WR-ALC office symbol</i>)
MMRRIA	APR-38 Unit, EW Integrated Systems Section, Engineering and Reliability

	Branch, Electronic Warfare (EW) Management Division, Directorate of Material Management (<i>WR-ALC office symbol</i>)
MMRRIC	EF-111/ALQ-125 Unit, EW Integrated Systems Section, Engineering and Reliability Branch, Electronic Warfare (EW) Management Division, Directorate of Material Management (<i>WR-ALC office symbol</i>)
MMRRV	Radar Warning Receiver Section, Engineering and Reliability Branch, Electronic Warfare (EW) Management Division, Directorate of Material Management (<i>WR-ALC office symbol</i>)
MMRRVE	ALR-74/F-15 TEWS Unit, Radar Warning Receiver Section, Engineering and Reliability Branch, Electronic Warfare (EW) Management Division, Directorate of Material Management (<i>WR-ALC office symbol</i>)
NCO	Non-commissioned officer
NCOIC	Non-commissioned officer in charge
OPF	Operational Flight Program
OGP	Operational Ground Program
OO-ALC	Ogden Air Logistics Center
/MAKTF	Software Support Center Branch, Missile and Aircraft Systems Division, Directorate of Maintenance (<i>OO-ALC office symbol</i>)
/MMEC	Aircraft Computer Resources Branch, Engineering Division, Directorate of Material Management (<i>OO-ALC office symbol</i>)
/MMECA	F-16 Fire Control/HUD OPF Development Section, Aircraft Computer Resources Branch, Engineering Division, Directorate of Material Management (<i>OO-ALC office symbol</i>)
/MMECR	F-16 Radar/Stores OPF Development Section, Aircraft Computer Resources Branch, Engineering Division, Directorate of Material Management (<i>OO-ALC office symbol</i>)
/MMECT	F-4 AISF Section, Aircraft Computer Resources Branch, Engineering Division, Directorate of Material Management (<i>OO-ALC office symbol</i>)
OTP	Operational Test Program
PACAF	Pacific Air Forces
PDSS	Post Deployment Software Support
PMD	Program Management Directive
PROM	Programmable read-only memory
RF	Radio Frequency
RWA	Inter-Command Electronic Warfare Management Directorate (ICEWMD), Aeronautical Systems Division (<i>functional office symbol</i>)
SAC	Strategic Air Command
/LG	Deputy for Logistics (<i>office symbol</i>)
/LGMMMD	Logistics Maintenance Management Data Branch (<i>office symbol</i>)
SEI	Software Engineering Institute
SGML	Standard Generalized Markup Language
SMDPS	Strategic Mission Data Planning System
SPM	System Program Manager
SPO	Systems Program Office
SRU	Shop Replaceable Unit
SSC	Software Support Center
SSE	Software Support Environment
TAC	Tactical Air Command
TAWC	Tactical Air Warfare Center
TDLA	Maintenance Evaluator for Avionics Maintenance Squadron (<i>office symbol</i>)
TDS	Deputy for Software (<i>office symbol</i>)
TFW	Tactical Fighter Wing
TODO	Technical Order Distribution Officer
TPS	Test Program Set
USAF	United States Air Force

USAFE	United States Air Forces in Europe
USAFR	United States Air Force Reserve (<i>see also AFRES</i>)
UUT	Unit under test
WR-ALC	Warner Robins Air Logistics Center
/MAI	Airborne Electronics Division, Directorate of Maintenance (<i>WR-ALC office symbol</i>)
/MAIT	Software Support Center Branch, Airborne Electronics Division, Directorate of Maintenance (<i>WR-ALC office symbol</i>)
/MAITB	Radar and Space Communications Section, Software Support Center Branch, Airborne Electronics Division, Directorate of Maintenance (<i>WR-ALC office symbol</i>)
/MAITBC	Countermeasures Unit, Radar and Space Communications Section, Software Support Center Branch, Airborne Electronics Division, Directorate of Maintenance (<i>WR-ALC office symbol</i>)
/MAITC	Tactical Support Section, Software Support Center Branch, Airborne Electronics Division, Directorate of Maintenance (<i>WR-ALC office symbol</i>)
/MAITCA	F-15 Radar Support Unit, Tactical Support Section, Software Support Center Branch, Airborne Electronics Division, Directorate of Maintenance (<i>WR-ALC office symbol</i>)
/MMEC	Integration Support Facility Operations Branch, Systems Engineering Division, Directorate of Material Management (<i>WR-ALC office symbol</i>)
/MMR	Electronic Warfare (EW) Management Division, Directorate of Material Management (<i>WR-ALC office symbol</i>)
/MMRR	Engineering and Reliability Branch, Electronic Warfare (EW) Management Division, Directorate of Material Management (<i>WR-ALC office symbol</i>)
/MMRRA	Emergency Reprogramming Center, Simulation and Evaluation Section, Engineering and Reliability Branch, Electronic Warfare (EW) Management Division, Directorate of Material Management (<i>WR-ALC office symbol</i>)
/MMRRC	EW Active Systems Section, Engineering and Reliability Branch, Electronic Warfare (EW) Management Division, Directorate of Material Management (<i>WR-ALC office symbol</i>)
/MMRRIA	APR-38 Unit, EW Integrated Systems Section, Engineering and Reliability Branch, Electronic Warfare (EW) Management Division, Directorate of Material Management (<i>WR-ALC office symbol</i>)
/MMRRIC	EF-111/ALQ-125 Unit, EW Integrated Systems Section, Engineering and Reliability Branch, Electronic Warfare (EW) Management Division, Directorate of Material Management (<i>WR-ALC office symbol</i>)
/MMRRV	Radar Warning Receiver Section, Engineering and Reliability Branch, Electronic Warfare (EW) Management Division, Directorate of Material Management (<i>WR-ALC office symbol</i>)
/MMRRVE	ALR-74/F-15 TEWS Unit, Radar Warning Receiver Section, Engineering and Reliability Branch, Electronic Warfare (EW) Management Division, Directorate of Material Management (<i>WR-ALC office symbol</i>)
XRI	HQ USAF, AFCOLR, Plans & Programs Division, Information Systems Branch (<i>office symbol</i>)

Appendix B: Software Blue Two Visit Fact-Finding Participants

Air Force Coordinating Office for Logistics Research (HQ USAF)

Capt. Benita L. Gilliard
Air Force Coordinating Office
for Logistics Research
(HQ USAF)
AFCOLR/XRI
Wright-Patterson AFB, OH 45433-5000
Office Phone: 513-255-4758
AV 785-4758

CMSgt. Charles M. Worm
Air Force Coordinating Office
for Logistics Research
(HQ USAF)
AFCOLR/MEI
Wright-Patterson AFB, OH 45433-5000
Office Phone: 513-255-4758
AV 785-4758

Aeronautical Systems Division

Landon O. Sager
Inter-Command Electronic
Warfare Management Directorate,
Aeronautical Systems Division
ASD/RWA
Wright-Patterson AFB, OH 45433-5000
Office Phone: 513-255-2108
AV 785-2108

Software Engineering Institute

William E. Hefley
Software Engineering Institute
Carnegie Mellon University
Pittsburgh, PA 15213
Office Phone: 412-268-7793

Ogden Air Logistics Center

Rick Holsman
Ogden Air Logistics Center
OO-ALC/MMEC
Hill AFB, UT 84056-5000
Office Phone: 801-777-7355
AV 458-7355

Major Gary S. Hochstetler, USAFR
Ogden Air Logistics Center
OO-ALC/MMEC
Hill AFB, UT 84056-5000

Leon Oldham
Ogden Air Logistics Center
OO-ALC/MMECR
Hill AFB, UT 84056-5000
Office Phone: 801-777-7232
AV 458-7232

Bruce W. Rudd
Ogden Air Logistics Center
OO-ALC/MMECA
Hill AFB, UT 84056-5000
Office Phone: 801-777-7336
AV 458-7336

Robert Sharp
Ogden Air Logistics Center
OO-ALC/MAKTF
Hill AFB, UT 84056-5000
Office Phone: 801-777-7855
AV 458-7855

Bill Frost
Ogden Air Logistics Center
OO-ALC/MMECT
Hill AFB, UT 84056-5000

388th Tactical Fighter Wing

TSgt. Jeffrey A. Carey
388 CRS/MACIA
Hill AFB, UT 84056-5000
Office Phone: 801-777-5494
AV 458-5494

TSgt. Rudolph W. Peart
388 CRS/MACIA
Hill AFB, UT 84056-5000
Office Phone: 801-777-5494
AV 458-5494

SSgt. Christopher B. Gifford
388 AGS/MAABC
Hill AFB, UT 84056-5000
Office Phone: 801-777-3448
AV 458-3448

Strategic Air Command

Capt. Daniel R. Bliss
Headquarters, Strategic Air Command
HQ SAC/LGMMD
Offutt AFB, NE 68113
Office Phone:
AV 271-5627

96th Bombardment Wing (Heavy)

Capt. Steve Hackett
96 BMW/MAMC
Dyess AFB, TX 79607
Office Phone: 915-696-2653
AV 461-2653

CMSgt. Robert Lewis
96 BMW/MAP
Dyess AFB, TX 79607

Air Force Operational Test & Evaluation Center

Major Gary F. Giesecke
AFOTEC B-1B FOT & E/TDS
Dyess AFB, TX 79607
Office Phone: 915-696-4436
AV 461-4436

Capt. Glenn Tuley
AFOTEC B-1B FOT & E/TDS
Dyess AFB, TX 79607
Office Phone: 915-696-4428
AV 461-4428

1Lt. Rich Dale
AFOTEC B-1B FOT & E/TDS
Dyess AFB, TX 79607
Office Phone: 915-696-4424
AV 461-4424

2Lt. Emily Andrew
AFOTEC B-1B FOT & E/TDS
Dyess AFB, TX 79607
Office Phone: 915-696-4433
AV 461-4433

MSgt Mel Noble
AFOTEC B-1B FOT & E/TDLA
Dyess AFB, TX 79607
Office Phone: 915-696-3182
AV 461-3182

SSgt. W. R. Wanamaker
AFOTEC B-1B FOT & E/TDLA
Dyess AFB, TX 79607
Office Phone: 915-696-4411
AV 461-4411

Warner Robins Air Logistics Center

John J. LaVecchia
Warner Robins Air Logistics Center
WR-ALC/MMRR
Robins AFB, GA 31098-5149
Office Phone: 912-926-5948
AV 468-5948

Harry Jennings
Warner Robins Air Logistics Center
WR-ALC/MMRRA
Robins AFB, GA 31098-5149
Office Phone: 912-926-4611
AV 468-4611

Dorothy Jackson
Warner Robins Air Logistics Center
WR-ALC/MMRRIC
Robins AFB, GA 31098-5149
Office Phone: 912-926-4926
AV 468-4926

Joseph Watwood
Warner Robins Air Logistics Center
WR-ALC/MMRRIA
Robins AFB, GA 31098-5149
Office Phone: 912-926-4617
AV 468-4617

Jerry L. Watts
Warner Robins Air Logistics Center
WR-ALC/MAITBC
Robins AFB, GA 31098-5149
Office Phone: 912-926-3207
AV 468-3207

Michael S. Tipton
Warner Robins Air Logistics Center
WR-ALC/MMRRC
Robins AFB, GA 31098-5149
Office Phone: 912-926-4525
AV 468-4525

Charles R. Singleton
Warner Robins Air Logistics Center
WR-ALC/MAITC
Robins AFB, GA 31098-5149
Office Phone: 912-926-5061
AV 468-5061

William Calkins
Warner Robins Air Logistics Center
WR-ALC/MMRRV
Robins AFB, GA 31098-5149
Office Phone: 912-926-4896
AV 468-4896

Jim Mosely
Warner Robins Air Logistics Center
WR-ALC/MAITCA
Robins AFB, GA 31098-5149
Office Phone: 912-926-5061
AV 468-5061

Roy P. Oliver
Warner Robins Air Logistics Center
WR-ALC/MMRRVE
Robins AFB, GA 31098-5149
Office Phone: 912-926-2588
AV 468-2588

William Raymond Haggard
Warner Robins Air Logistics Center
WR-ALC/MMEC
Robins AFB, GA 31098-5149
Office Phone: 912-926-3934
AV 468-3934

Larry K. Israel
Warner Robins Air Logistics Center
WR-ALC/MAIT
Robins AFB, GA 31098-5149
Office Phone: 912-926-2457
AV 468-2457

Lonnie Y. Totty
Warner Robins Air Logistics Center
WR-ALC/MAITB
Robins AFB, GA 31098-5149
Office Phone: 912-926-4725
AV 468-4725

Appendix C: Ogden Air Logistics Center Briefing

Table of Contents

1. Introduction	3
1.1. Blue Two Visit Program	3
1.2. Software Blue Two Visit	4
1.3. Feasibility Assessment	5
2. Fact-finding Visits	7
2.1. Hill Air Force Base	9
2.2. Dyess Air Force Base	10
2.3. Robins Air Force Base	11
3. Software Issues	15
3.1. Weapon System Orientation	15
3.2. Acquisition Issues	18
3.3. Post Deployment Software Support Issues	21
3.4. Software Development Issues	22
3.5. Supportability and Testability Issues	25
3.6. Personnel Management Issues	26
4. Recommendations	29
4.1. Software Blue Two Visit Messages	29
4.2. Communicating the Software Messages	30
4.3. Targeting the Message	33
4.4. Identifying the Software Blue Two Visit	33
5. Conclusion	35
Appendix A. List of Acronyms and Office Symbols	37
Appendix B. Software Blue Two Visit Fact-Finding Participants	41
Appendix C. Ogden Air Logistics Center Briefing	45

List of Figures

Figure 2-1:	Major Participants in this Feasibility Assessment	8
Figure 3-1:	ALC Efforts in AISF and Software Support Centers	17
Figure 3-2:	Planned Approach to B-1B Data Processing	23
Figure 3-3:	Desired Separation of OFP and Mission Data	24
Figure 4-1:	U.S. Air Force Software Inventory (adapted from AF and AFLC Regulations)	31
Figure 4-2:	Components of a Typical Avionics Integration Support Facility (AISF)	32

List of Tables

Table 2-1: AFCOLR Fact-Finding Team	7
Table 2-2: Participants from Hill AFB	10
Table 2-3: Participants from Dyess AFB	11
Table 2-4: Participants from Robins AFB	12
Table 3-1: Maintainer Responsibilities for Software	16